



Quick Installation Guide

N300 Wi-Fi xPON ONT

HG3

Package contents

- xPON ONT x 1
- Power adapter x 1
- Ethernet cable x 1
- User manual x 1

For product or function details, please go to www.tendacn.com to download the user guide.

Get to know the ONT

LED indicators



LED indicator	Color	Status	Description
PWR	Green	Solid on	The ONT is powered on properly.
		Off	The ONT is powered off or not powered on properly.
PON	Green	Solid on	The ONT is registered successfully.
		Blinking	The registration is not completed (unregistered or registering).
		Off	The received optical power is lower than the optical receiver sensitivity, or no fiber cord is connected.
LOS	Red	Blinking	The received optical power is lower than the optical receiver sensitivity.
		Off	The received optical power is within the optical receiver sensitivity.
LAN	Green	Solid on	There is at least one LAN port connected properly, but no data is being transmitted over the corresponding port.
		Blinking	There is at least one LAN port connected properly, and data is being transmitted over the corresponding port.
		Off	No Ethernet device is connected or the Ethernet device is not connected to any LAN port properly.
WLAN	Green	Solid on	The Wi-Fi network is enabled, but no data is being transmitted wirelessly.
		Blinking slowly (0.5s)	The Wi-Fi network is enabled, and data is being transmitted wirelessly.
		Blinking quickly (0.25s)	The ONT is performing or pending for WPS negotiation.
		Off	The Wi-Fi network is disabled.

Ports & Button

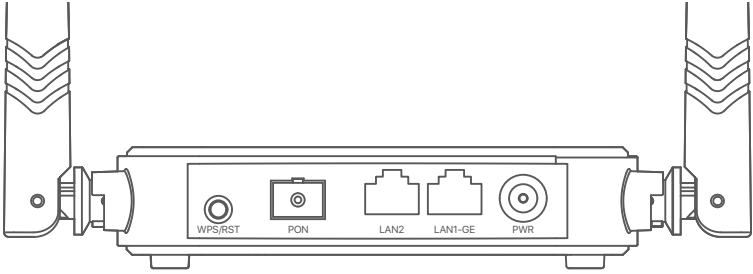

Port/Button	Description
WPS/RST	<p>WPS/Reset button.</p> <ul style="list-style-type: none"> • WPS: Wi-Fi-enabled devices can connect to the Wi-Fi networks of the ONT without entering the password through WPS negotiation. Press the button for 1 to 3 seconds to start the WPS negotiation process of the ONT. The WLAN LED indicators blink quickly. Within 2 minutes, enable the WPS function on a WPS-supported device to establish a WPS connection. • Reset: Restore the ONT to the configurations preset by the ISP. After the ONT completes startup, press the button for more than 10 seconds and release it. All LED indicators will light off in a few seconds. When the PWR LED indicator lights solid on again, the ONT is restored to the configurations preset by the ISP.
PON	<p>Optical fiber port. Used to connect to a fiber cord.</p>
LAN1-GE/LAN2	<p>LAN1-GE: 1000 Mbps LAN port LAN2: 100 Mbps LAN port Used to connect to a router, switch, computer or IPTV set-top box.</p>
PWR	<p>Power jack. Please use the included power adapter to connect the ONT to a power source.</p>

1. Connect and register the ONT



Caution, laser

DO NOT look directly at the **PON** port when the device is powered on, as well as the terminal of the indoor fiber cord, to prevent any harm to your eyes.

Connect the ONT as shown in the figure. The ONT automatically adapts to the fiber access type. Wait until the **PON** LED indicator lights solid on, then the ONT is registered successfully.

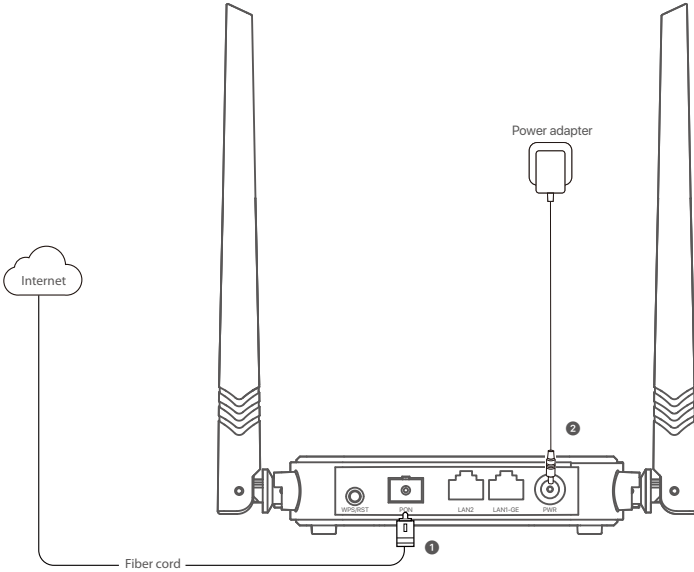

Tips:

If your ISP provides any parameters for registration, you can use them to manually register the ONT.

Method:

- 1 Use an Ethernet cable to connect a LAN port of the ONT to a computer, or connect your smartphone to the Wi-Fi network of the ONT using the **SSID** (Wi-Fi name) and **Key** (Wi-Fi password) on the bottom label.
- 2 Enter **192.168.1.1** in a web browser and log in to the web UI of the ONT (default login user name and password are both **admin**).
- 3 Navigate to **Admin > GPON Settings** (or **EPON Settings**) and enter the parameters provided by ISP.

2. Configure the internet access

Tips:

Choose a desired mode to configure your internet access:

- Router mode: Choose this mode if your internet access type is PPPoE or DHCP.
- Bridge mode (default): Choose this mode if your internet access type is PPPoE.

Router mode

Option 1 Access internet over PPPoE

Step 1: Log in to the web UI

- 1 Connect a LAN port of the ONT to a computer using an Ethernet cable, or connect your smartphone to the Wi-Fi network of the ONT using the **SSID** (Wi-Fi name) and **Key** (Wi-Fi password) on the bottom label.
- 2 Start a web browser and visit **192.168.1.1**.
- 3 Enter the **User Name** and **Password** (**admin** for both by default).
- 4 Click **Login**.

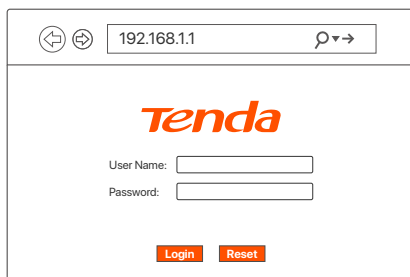

The screenshot shows a web browser window with the address bar containing "192.168.1.1". The main content area displays the "Tenda" logo in orange. Below the logo are two input fields: "User Name:" and "Password:". At the bottom of the form are two buttons: "Login" and "Reset", both in orange.

Tips:

If the above page does not appear, refer to **Q1** in **FAQ**.

Step 2: Set up a WAN connection

- 1 Choose **WAN > PON WAN**.
- 2 Tick **Enable VLAN**, and enter the **VLAN ID** provided by your ISP.
- 3 Set **Channel Mode** to **PPPoE**.
- 4 Set **Connection Type** to **INTERNET**.
- 5 Enter the PPPoE **UserName** and **Password** provided by your ISP.
- 6 Set other parameters according to your ISP and your own need.
- 7 Click **Apply Changes**.

PON WAN

This page is used to configure the parameters for PONWAN

nas0_0 ▾

Enable VLAN:	<input checked="" type="checkbox"/>
VLAN ID:	<input type="text"/>
802.1p_Mark	0 ▾
Multicast Vlan ID: [1-4094]	<input type="text"/>
Channel Mode:	PPPoE ▾
Enable Bridge:	<input type="checkbox"/>
Bridge Mode:	Bridged Ethernet (Transparent Bridging)
Admin Status:	<input checked="" type="radio"/> Enable <input type="radio"/> Disable
Connection Type:	INTERNET ▾
MTU:	1492
Enable IGMP-Proxy:	<input type="checkbox"/>
Enable MLD-Proxy:	<input type="checkbox"/>
IP Protocol:	IPv4 ▾

PPP Settings:

UserName:	<input type="text"/>
Password:	<input type="text"/>
Type:	Continuous ▾
AC Name:	<input type="text"/>
Service-Name:	<input type="text"/>

Port Mapping:

<input type="checkbox"/> LAN_1	<input type="checkbox"/> LAN_2
<input type="checkbox"/> WLAN0	
<input type="checkbox"/> WLAN0-AP1	<input type="checkbox"/> WLAN0-AP2
<input type="checkbox"/> WLAN0-AP3	<input type="checkbox"/> WLAN0-AP4

Apply Changes **Delete**

Done.

To access the internet:

- Connect your wired device, such as a computer, to a LAN port of the ONT.
- Connect your wireless device, such as a smartphone, to the Wi-Fi network of the ONT using the **SSID** (Wi-Fi name) and **Key** (Wi-Fi password) on the bottom label.



Tips:

- If you cannot access the internet after the configuration, refer to **Q2** in **FAQ**.
- If you want to change the Wi-Fi name and password, refer to **Q5** in **FAQ**.

Option 2 Access internet over DHCP

Step 1: Log in to the web UI

Refer to [Step 1: Log in to the web UI](#) in [Option 1 Access internet over PPPoE](#) under **Router mode** to log in to the web UI of the ONT.

Step 2: Set up a WAN connection

- 1 Choose **WAN > PON WAN**.
- 2 Tick **Enable VLAN**.
- 3 Enter the **VLAN ID** provided by your ISP.
- 4 Set **Channel Mode** to **IPoE**.
- 5 Set **Connection Type** to **INTERNET**.
- 6 Click **Apply Changes**.

PON WAN

This page is used to configure the parameters for PONW

nas0_0 ▾

Enable VLAN:	<input checked="" type="checkbox"/>
VLAN ID:	<input type="text"/>
802.1p_Mark	0 ▾
Multicast Vlan ID: [1-4094]	<input type="text"/>
Channel Mode:	IPoE ▾
Enable Bridge:	<input type="checkbox"/>
Bridge Mode:	Bridged Ethernet (Transparent Bridging)
Admin Status:	<input checked="" type="radio"/> Enable <input type="radio"/> Disable
Connection Type:	INTERNET ▾
MTU:	1500
Enable IGMP-Proxy:	<input type="checkbox"/>
Enable MLD-Proxy:	<input type="checkbox"/>
IP Protocol:	IPv4 ▾

WAN IP Settings:

Type:	<input type="radio"/> Fixed IP <input checked="" type="radio"/> DHCP
Local IP Address:	0.0.0.0
Remote IP Address:	0.0.0.0
Subnet Mask:	255.255.255.0
IP Unnumbered	<input type="checkbox"/>
Request DNS	<input checked="" type="radio"/> Enable <input type="radio"/> Disable
Primary DNS Server	<input type="text"/>
Secondary DNS Server	<input type="text"/>

Port Mapping:

<input type="checkbox"/> LAN_1	<input type="checkbox"/> LAN_2
<input type="checkbox"/> WLANO	
<input type="checkbox"/> WLANO-AP1	<input type="checkbox"/> WLANO-AP2
<input type="checkbox"/> WLANO-AP3	<input type="checkbox"/> WLANO-AP4

Apply Changes **Delete**

Done.

To access the internet:

- Connect your wired device, such as a computer, to a LAN port of the ONT.
- Connect your wireless device, such as a smartphone, to the Wi-Fi networks of the ONT, using the **SSID** (Wi-Fi name) and **Key** (Wi-Fi password) on the bottom label.

Tips:

- If you cannot access the internet after the configuration, refer to **Q2 in FAQ**.
- If you want to change the Wi-Fi name and Wi-Fi password, refer to **Q5 in FAQ**.

Bridge mode

Tips:

When the ONT is set to Bridge mode, please configure internet settings based on ISP requirements.

Access internet over PPPoE

- 1 Connect a LAN port of the ONT to the WAN port of a router using an Ethernet cable.
 - 2 Connect your computer to a LAN port of the router using an Ethernet cable.
 - 3 Set up a PPPoE connection on the router as required.
- After the settings, you can access the internet through the router.

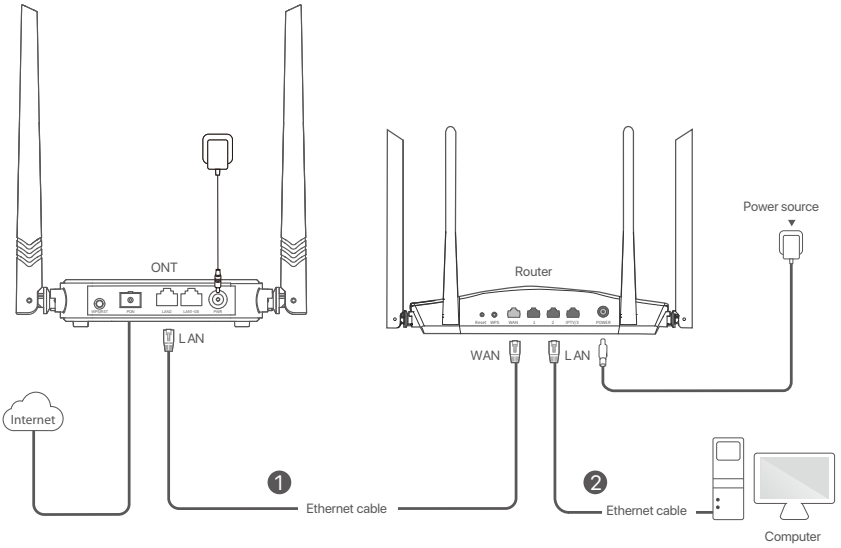

FAQ

Q1: I cannot log in to the web UI by visiting 192.168.1.1. What should I do?

A1: Try the following solutions:

- Ensure that the ONT is powered on properly (the **PWR** LED indicator is solid green).
- If you use a wireless device, such as a smartphone, to configure the ONT:
 - Ensure that your smartphone has disabled mobile data and is connected to the Wi-Fi network of the ONT.
 - Clear the cache of the web browser or change a web browser and try again.
 - Use another smartphone and try again.
- If you use a wired device, such as a computer, to configure the ONT:
 - Ensure that your computer is connected to the ONT properly (the **LAN** LED indicator of the connected port lights up).
 - Ensure that your computer is set to obtain an IP address automatically.
 - Ensure that the IP address of your computer is at the same network segment as the ONT.
 - Use another computer and try again.
- Reset the ONT (after the ONT completes startup, press the WPS/RST button down for more than 10 seconds and release it. All LED indicators light off in a few seconds. When the PWR LED indicator lights solid on again, the ONT is reset) and try again.

Q2: I cannot access the internet after the configuration. What should I do?

A2: Try the following solutions:

- Check the LED indicator status of ONT:
 - If the **PWR** LED indicator is off, ensure that the ONT is powered on properly.
 - If the **LOS** LED indicator blinks, ensure that the PON port is clean and connected properly, the fiber cord is not bent excessively and the input optical power is within the normal range (Rx Power between -28 dBm to -8 dBm on the **Status > PON** page).
 - If the **PON** LED indicator blinks, the ONT is not registered. Contact your ISP or verify the parameters for registration are correct.
- Ensure that your ISP supports self-purchased PON devices for internet access.
- If you set the ONT to the router mode:
 - Ensure that the ONT obtains a valid IP address and gateway on the **Status > Device > WAN Configuration** page. If not, the WAN connection is not set up successfully. Verify the parameters are correct.
 - Ensure that the wired device is connected to a LAN port of the ONT or downstream router (if any) properly and set to obtain an IP address automatically.
 - Ensure that the wireless device is connected to the Wi-Fi network of the ONT or downstream router (if any).
- If you set the ONT to the bridge mode, ensure that the router or computer used for dial up is connected and configured properly.

If the problem persists, consult your ISP.

Q3: I cannot find the Wi-Fi signal of the ONT on my wireless device. What should I do?

A3: Ensure that the **WLAN** LED indicator lights up. If not, the Wi-Fi networks of the ONT are disabled.

Enable the Wi-Fi networks of the ONT by performing the operations below and try again.

Enable Wi-Fi networks: Connect a wired device, such as a computer, to the ONT and log in to the web UI of the ONT. Choose **WLAN > Basic Settings** and deselect **Disable WLAN Interface** and save the configurations.

Q4: How to reset the ONT?

A4: Method1: After the ONT completes startup, press the WPS/RST button for more than 10 seconds and release it. All LED indicators will light off in a few seconds. When the PWR LED indicator lights solid on again, the ONT is reset.

Method2: Log in to the web UI of the ONT, choose **Admin > Backup/Restore** and click **Reset** on the page.

Q5: How to change the Wi-Fi name and password?

A5: Log in to the web UI of the ONT, and choose **WLAN**:

- Wi-Fi name: Choose **Basic Settings**, change the **SSID** (Wi-Fi name) and click **Apply Changes**.
- Wi-Fi password: Choose **Security**, set **Encryption** to **WPA2 Mixed** (recommended) and change the **Pre-Shared Key** (Wi-Fi password). Then, click **Apply Changes**.

Safety Precautions

Before performing an operation, read the operation instructions and precautions to be taken, and follow them to prevent accidents. The warning and danger items in other documents do not cover all the safety precautions that must be followed. They are only supplementary information, and the installation and maintenance personnel need to understand the basic safety precautions to be taken.

- Do not use the device in a place where wireless devices are not allowed.
- Please use the included power adapter.
- Mains plug is used as the disconnect device, and shall remain readily operable.
- The power socket shall be installed near the device and easily accessible.
- Operating environment: Temperature: 0 C to 45 C ; Humidity: (10% - 90%) RH, non-condensing;
Storage environment: Temperature: -40 C to +70 C ; Humidity: (5% - 90%) RH, non-condensing.
- Keep the device away from water, fire, high electric field, high magnetic field, and inflammable and explosive items.
- Unplug this device and disconnect all cables during lightning storms or when the device is unused for long periods.
- Do not use the power adapter if its plug or cord is damaged.
- If such phenomena as smoke, abnormal sound or smell appear when you use the device, immediately stop using it and disconnect its power supply, unplug all connected cables, and contact the after-sales service personnel.
- Disassembling or modifying the device or its accessories without authorization voids the warranty, and might cause safety hazards.

© 2022 Shenzhen Tenda Technology Co., Ltd. All rights reserved.

Tenda is a registered trademark legally held by Shenzhen Tenda Technology Co., Ltd. Other brand and product names mentioned herein are trademarks or registered trademarks of their respective holders. Specifications are subject to change without notice.

Technical Support

Shenzhen Tenda Technology Co., Ltd.

Floor 6-8, Tower E3, No.1001, Zhongshanyuan Road, Nanshan District, Shenzhen, China. 518052

USA hotline: 1-800-570-5892

Toll Free: 7 x 24 hours

Canada hotline: 1-888-998-8966

Toll Free: Mon - Fri 9 am - 6 pm PST

Hong Kong hotline: 00852-81931998

Global hotline: +86 755-2765 7180 (China Time Zone)

Website: www.tendacn.com

E-mail: support@tenda.com.cn